

## Speed Control Unit ESD5500E SERIES

The ESD5500E Series speed control unit is designed to precisely control engine speed with rapid responses to transient load changes. The ESD speed control is compatible with all GAC proportional actuators except the ACB2001 electric actuator since this high torque actuator also requires current limiting. Ruggedly built to withstand all engine environments, the ESD's STARTING FUEL and SPEED RAMP features will minimize engine exhaust smoke experienced prior to attaining engine operating speed and smooth out response.

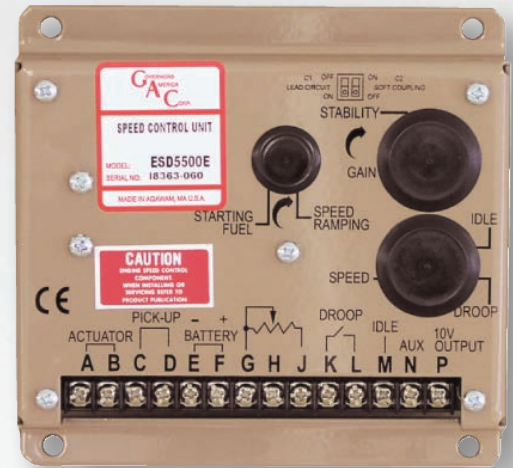

### FEATURES

- Simple Installation and Adjustability
- Environmentally Protected
- Adjustable Droop and Idle Circuits
- Accessory Inputs for Load Sharing
- Variable Speed Operation
- Reverse Battery Voltage Protected
- Soft Coupling & Lead Circuit Options

### SELECTION CHART / DIMENSIONS

	Standard Features	Light Force	ATB Applications	GASEOUS		
				Anti-Windup Circuit	25-45mm Small Bore ATB	55-95mm Large Bore ATB
ESD5500E	•					
ESD5520E		•				
ESD5526E			•	•	•	
ESD5528E			•	•		•

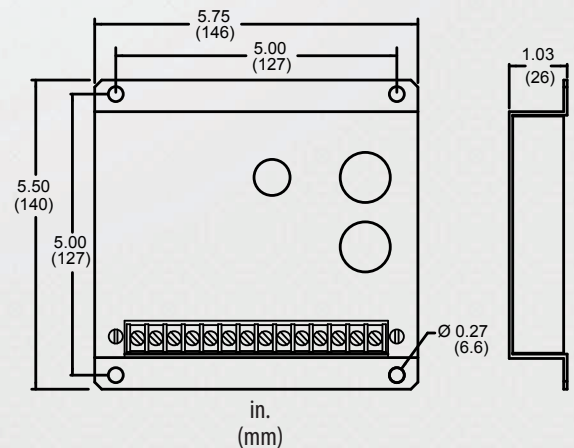

# ACCESSORIES

## Magnetic Speed Pickups



The Magnetic Speed Sensor detects when ring gear teeth, or other ferrous projections, pass the tip of the sensor. Electrical impulses are produced by the sensor's internal coil and sent to the speed control unit. The signal from the magnetic speed sensor, teeth per second (Hz.), is directly proportional to engine speed. Speed sensors are available in various lengths in both U.S. and metric threads. Wire leads, military connectors, automotive connectors or stud terminals are also available. Over 30 styles currently available.

# SPECIFICATIONS

## Performance

Isochronous Operation	±0.25%
Speed Range	1 - 7.5 KHz Continuous
Speed Drift with Temperature	±1%
Idle Speed Adjust CW	60% of Set Speed
Idle Speed Adjust CCW	Less than 1200 Hz
Droop Range	1 - 5% Regulation
Droop Adj. Max. (K-L Jumpered)	400 Hz., ±75 Hz per 1.0 A change
Droop Adj. Min. (K-L Jumpered)	15 Hz., ±75 Hz per 1.0 A change
Speed Trim Range	±200 Hz
Remote Variable Speed Range	500 - 7.5 KHz
Terminal Sensitivity	
J	100 Hz., ±15 Hz/Volt @ 5 KΩ Impedance
L	735 Hz., ±60 Hz/Volt @ 65 KΩ Impedance
N	148 Hz., ±10 Hz/Volt @ 1 MΩ Impedance
P	10 VDC Supply @ 20 mA Max

## Environmental

Operating Temperature Range	-40 °F to +180 °F (-40 °C to +85 °C)
Relative Humidity	up to 95%
Vibration	1 G @ 20 - 100Hz
All Surface Finishes	Fungus Proof and Corrosion Resistant

## Electrical

Power Supply	12 or 24 VDC Battery Systems (Transient and Reverse Voltage Protected)
Polarity	Negative Ground (Case Isolated)
Power Consumption	50 mA plus Actuator Current
Actuator Current Range @ 77°F (25°C)	2.5 - 10 Amps Continuous
Speed Sensor Signal Range	0.5 - 50 VAC
Speed Sensor Signal	0.5 - 120 VRMS

## Physical

Dimensions	5.50 in x 5.75 in x 1.03 in (140 mm x 146 mm x 26 mm)
Weight	1.2 lb (0.544 kg)
Mounting	Any Position, Vertically Preferred

# OPTIONS

## GAC ACTUATORS

GAC actuators incorporate fast response, multi voltage usage, and a field proven electromechanical design that allows for precise control when coupled with GAC's speed control devices. All of GAC actuators are easy to install with no maintenance required.

- Throttle Body
- Engine Mounted
- Pump Mounted
- Universal



Governors America Corp.  
720 Silver Street Agawam, MA 01001  
Phone: 413.233.1888 Fax: 413.789.7736  
[www.governors-america.com](http://www.governors-america.com)  
[info@governors-america.com](mailto:info@governors-america.com)



8.13 PT11002E B

© 2013 Governors America Corp. All rights reserved.